

ECCENTRIC SPOT WELDING ELECTRODE

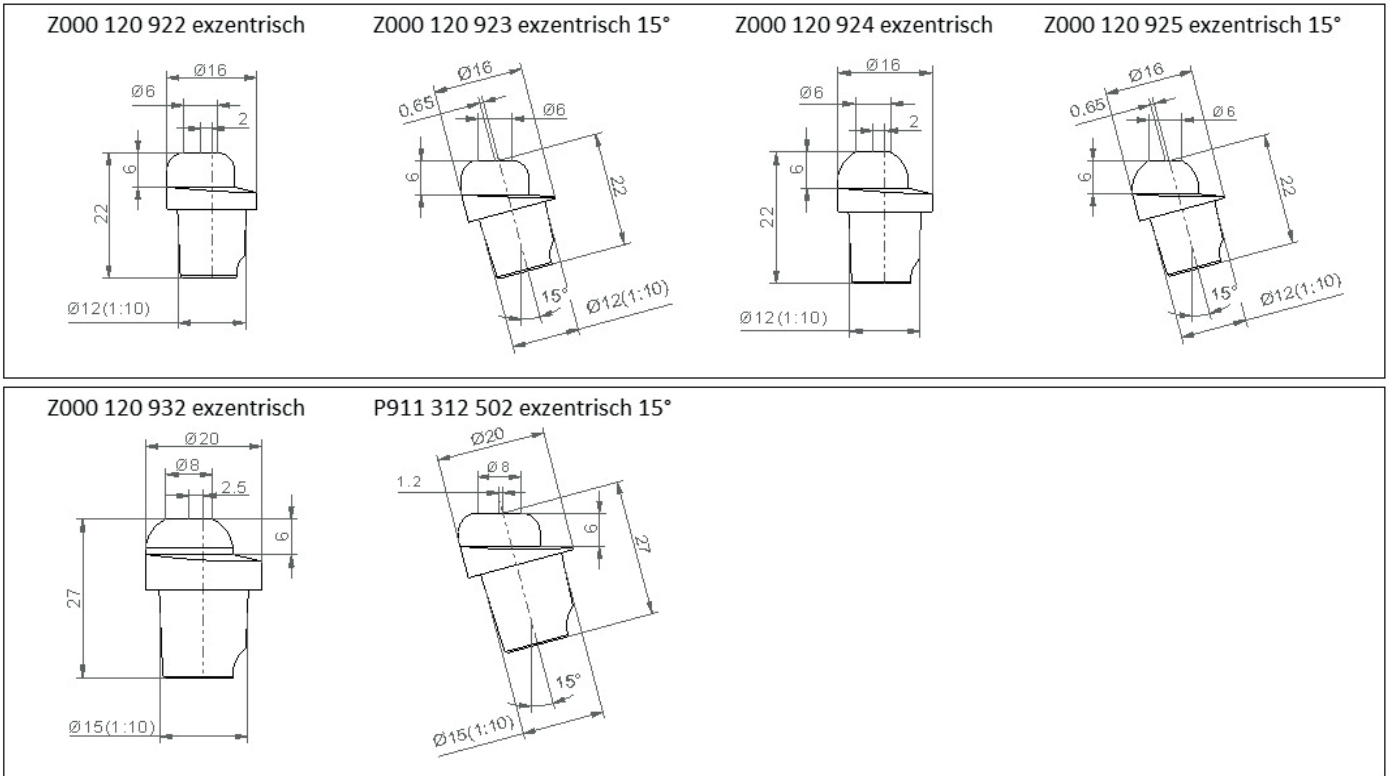

with double slope

